

***EASYLUX***  
***RETROREFLECTOMETER***

# WE ARE AHEAD.

EasyLux specializes in the design of precision optoelectronic measurement systems. Our innovative optical system is the result of more than 10 years of hard work by a non-conformist engineering team. We clearly realized how unsafe and unsuitable big and heavy instruments are for road visibility control.

The patented MINI retroreflectometer family is a turning point for the face of the standard retroreflectometers.

We are placing a new milestone. Change your concepts and leave the dinosaurs of retroreflectometers in the past.



EASYLUX  
RETROREFLECTOMETER



3  
MINI



32  
Classic Line



44  
Mobile &  
Software



**INNOVATION.**

## RETROREFLECTOMETER

A retroreflectometer is an optoelectronic instrument that translates the human visual perception to numbers.

**The MINI is a family of innovative retroreflectometers released in 2014** for on-site or laboratory measuring of retroreflection properties of road markings, road signs, road studs, safety clothing and other materials.

The exclusive external light suppression technology allows free access to the measurement area, even over strong sunlight.

On the following pages we will present our new technology and other innovations such as the quadruple angle vertical retroreflectometer and the dual angle road studs retroreflectometer.

CHANGE  
YOUR  
CONCEPTS

It is time to leave  
the big, heavy  
dinosaurs of  
retroreflectometers  
in the past.



**Creating an entirely new design meant inventing entirely new technology.**

**Arrangement B - The length of the illuminated area is fully included within the length of the detected area.**

# STRONG AND MODERN

Built with modern, strong and flexible engineering plastics, aluminum and inox steel structure, the new MINI is a light and robust retroreflectometer.

## MINI (MiniReflecto) Retroreflectometer family

The MiniReflecto handheld instruments are available in 3 different configurations:

- Horizontal, for retroreflection of road markings;
- Vertical, for retroreflection of traffic signs;
- Road Studs, for raised pavement markers - RRP.M.

## AA BATTERY SDCard

The MINI works with standard universal rechargeable AA batteries.

The LED optical system makes the instrument energy efficient and almost maintenance-free.

All measured data is stored as text files onto a removable SD Card.

The MINI works with rechargeable AA batteries.



# AIRPLANE BAGGAGE CARRY-ON

**All MINI family are airplane carry-on baggage size compatible.**

You can now bring the carrying case with you in the airplane cabin.

**Brains over brawn.**

You no longer need to break your back using a retroreflectometer.



# LOG DATABASE

The measurements are organized on LOG files that can register important parameters:

- Road Name;
- Milestone mark;
- Operator's name;
- Direction (north, south, east, west);
- Material (paint, thermoplastic, prismatic, ...);
- Color;
- Place (left border, center line, etc.);
- Free notes (dusty, wet, sectioned, ...)





# ANDROID APP

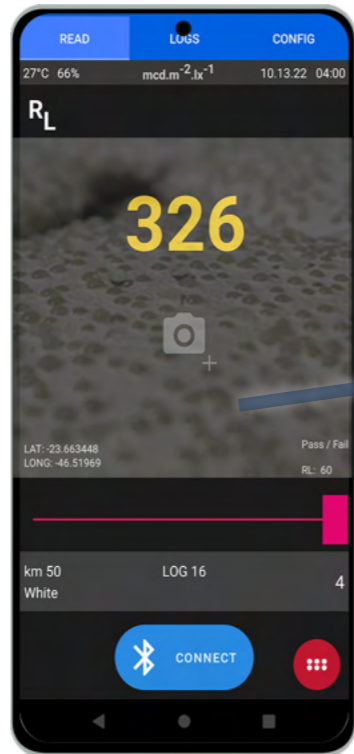

Trigger measurements.  
Share Data.  
Take Pictures





## ERGONOMIC ROAD MARKING CONTROL

Sun proof measurements.

# HORIZONTAL

## Retroreflectometer

EN1436	RL Qd
ASTM E1710	RL
ASTM E2302	Qd
ASTM E2177	RL wet
ASTM E2832	RL2 (rain)

MINI Horizontal measures the night visibility **RL**, the Day Visibility **Qd**, the visibility under wet **RL wet** and continuous wetting conditions **RL rain** of road markings.

The patented MINI retroreflectometer optical system, combined with CIE eye sensor response, allows precise measurement of all types and colors of road marking materials, even profiled markings up to 15 mm.

## Dimensions and Weight

Length	255 mm (without Qd)
Width	155 mm
Height	170 mm
Weight	2.1 kg (with battery)
Carrying case	470 x 380 x 240 mm

## Electrical

Battery	Standard rechargeable AA size (6 units)
Charger	Automatic 100-240 V full range
Data memory	SD Card (4 GB minimum) (> 1 000 000 data points)
Display	Color transfective, touch screen
Data Interface	USB , Bluetooth (optional)
Operating	-5°C to 50°C
Light source	LED light (maintenance free)

## SMALL AND FAST

### FAST Measurements:

0.5 s  $R_L$   
0.9 s  $R_L + Qd$

Our new technology is almost 5 times smaller and lighter than the classic old technology.

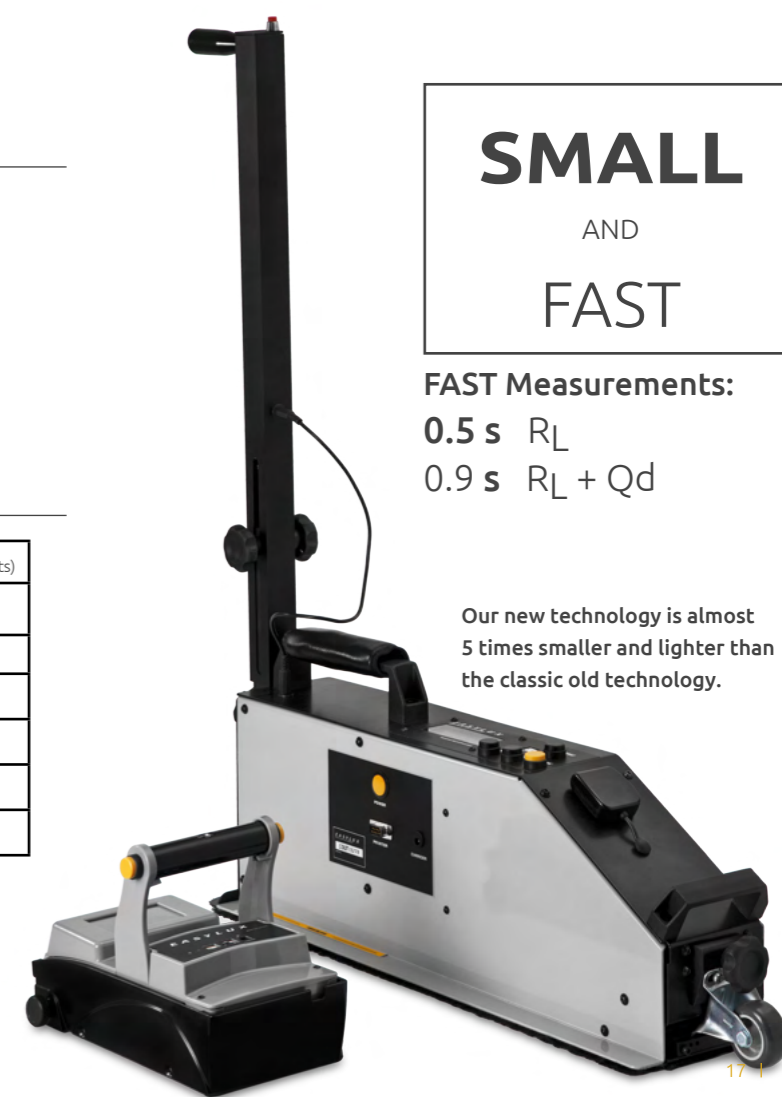

**WORK  
LIGHT**



## MINI Horizontal Features

- 30-meter geometry (15-meter 86.5°/1.5° available).
- Standard universal rechargeable AA battery.
- **External beam measurements for  $R_L$  and  $Q_d$ .**
- Open measurement area, allows see what you are testing.
- Android Smartphone Bluetooth interface (optional).
- Temperature, humidity and inclination (% Tilt X and % Tilt Y).
- GPS (optional).
- User removable SD Card (4 GB minimum).
- Color transfective (sun readable) LCD with touch screen.
- LED technology - almost maintenance-free.
- Airplane carry-on luggage compatible carrying case.
- Adjustable handle and IrDA remote control.
- Fast measurements: **0.7 s** for  $R_L$ , **0.3 s** for  $Q_d$ , **1 s** for  $R_L + Q_d$  .....*immediately ready for next measurement.*
- Measure flat and profiled markings up to 15 mm.
- Register the date, time, GPS, humidity, temperature, tilt %,...
- LOG facilities (Road name, milestone, color, material, ...)
- Free EasyData software for data analysis and reports.
- Calibration by ceramic reference - NIST / METAS traceable.

## MINI Horizontal Technical

Illumination angle	1.24° (88.76°)
Observation angle	2.29° (1.05°)
Geometry	30-meter simulation distance (15-meter available) <b>Arrangement B</b> - The length of the illuminated area is fully included within the length of the detected area.
Observation aperture	±0.15°
Measurement area	58 x 350 mm
Measurement sensor	CIE V ( $\lambda$ ) adapted
Measurement Range	$R_L$ : 0 - 4000 mcd . m <sup>2</sup> . lx <sup>-1</sup> $Q_d$ : 0 - 400 mcd . m <sup>2</sup> . lx <sup>-1</sup>
Measurement Time	<b>0.6 s</b> for $R_L$ , <b>0.9 s</b> for $R_L + Q_d$
Profiled markings	Up to 15 mm

**2 years warranty**

## Traceable Reference Standard

Easylux instruments are calibrated at a factory laboratory and traceable in accordance with standards issued by NIST or METAS.

**30-meter geometry:**

88.76° / 1.05° (ASTM E1710)

1.24° / 2.29° (EN1436)



**ASTM E2832**

$R_{L2}$  (rain) compatible technology.

External beam retroreflectometer.

Free access over measurement area.

# DIFFUSE LIGHT



## Qd

### Day visibility (optional)

The patented foldable and removable Qd light source makes the user work simple and practical. The Qd light source can be removed if Day Visibility (Qd) measurements are not required.

## Options

### MINI Horizontal add-ons

BlueTooth

WAAS GPS

Ergonomic KIT

Color CIE      ASTM 2367



CONVENIENT  
AND  
SMALLER

**15 mm**  
Profiled road markings  
with no adjustments.



# Approved

Test Certificate No. 0913-2014-04

Our innovative technology was approved  
by an independent laboratory in Germany.



# Approved

The MINI retroreflectometer technology was tested and certified by Russian Scientific Research Institute of Optical and Physical Measurements ~ VNIIOFI



# Conditions of rain.

## Continuous wetting RL-2 compatible technology.

Free access over measurement area.

ASTM E2832

EN 1436

ABNT 14723

The MINI retroreflectometer instrument has an external light beam. That is, the light shines out of the instrument housing and onto the roadway away from the instrument.

The external beam instruments are essential for measuring retroreflectivity in the falling rain condition ASTM E2832.





# LASER point

**Optional** high visibility green laser helps to find the measurement area, providing a visual reference point.

# CIE chromaticity

The Easylux MINI for road markings can measure the nighttime reflected colour coordinates – CIE chromaticity - of white and yellow markings.

The colour coordinates are stored for each measurement, classifying them as belonging or not to the ASTM colour box.

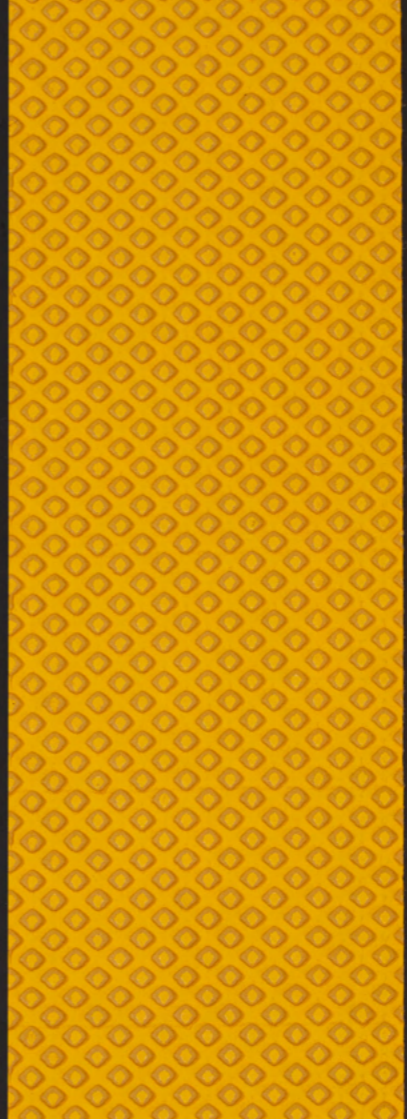

The MINI has an external light beam. That is, the light shines out of the instrument and onto the roadway, ahead of the instrument for measurements of RL, Qd and nighttime reflected colour coordinates.





# The Nylon Bag kit



MiniReflecto Horizontal measures the night visibility **RL**, the Day Visibility **Qd**, the visibility under wet **RL wet** and continuous wetting conditions **RL-2 rain** of all shapes and colors of road markings, even **RL** profiled up to 15 mm without adjustments.





- **Avoid Airplane extra fees.**
- **Avoid battery warnings.**
- **Increase the portability.**
- **Save space on the marking truck.**
- **Eliminate the operators fatigue by muscular effort.**
- **Speed up the processes of loading and unloading.**
- **Use standard AA-size batteries: easy to find and replace.**
- **External Beam technology (allows RL-2 rain test).**
- **15 mm profiled.**





The innovative design and unmatched portability saves space on the marking truck and speed up the processes of loading and unloading.



# VERTICAL

## Retroreflectometer

ASTM E1709	0.2°
ASTM E2540	0.5°
EN 12899-1	0.2°, 0.33°, 2.0°
ISO 20471	0.2°, 0.33°, 1.0°, 1.5°
ECE 104	0.33°

**The MINI Vertical** is an up to four angle retroreflectometer designed to accurately measure the retroreflection  $R_A$  of road signs, safety clothing and other materials.

**The innovative optical system can measure up to 4 (four) simultaneous observation angles. The entrance angle ( $\beta$ ) can be fixed ( $-4^\circ / +5^\circ$ ) or it can be continuously adjusted by the operator.**

The combination of adjustable entrance angle with the exclusive quadruple simultaneous observation angles allows precise determination of retroreflection according to all international standards.

## Dimensions and Weight

Length	255 mm
Width	155 mm
Height	170 mm
Weight	2.0 kg (with battery)
Carrying case	470 x 380 x 240 mm

## Electrical

Battery	Standard rechargeable - AA size (6 units)
Charger	Automatic 100-240 V full range
Data memory	SD Card (4 GB minimum) (> 1 000 000 data points)
Display	Color transfective, touch screen
Interface	USB, serial and Bluetooth (optional)
Operating	-10°C to 50°C
Light source	LED light (maintenance free)



# Extension

## Remote Control

Adjustable extension pole (0.6 m ~1.2 m) and a remote control make working with high-mounted traffic signs easy.

# Options

## MINI Vertical add-ons

- BlueTooth
- GPS
- RFID Reader ISO 15693 and ISO 1443A/B
- Barcode Reader
- Extension pole
- Color recognition

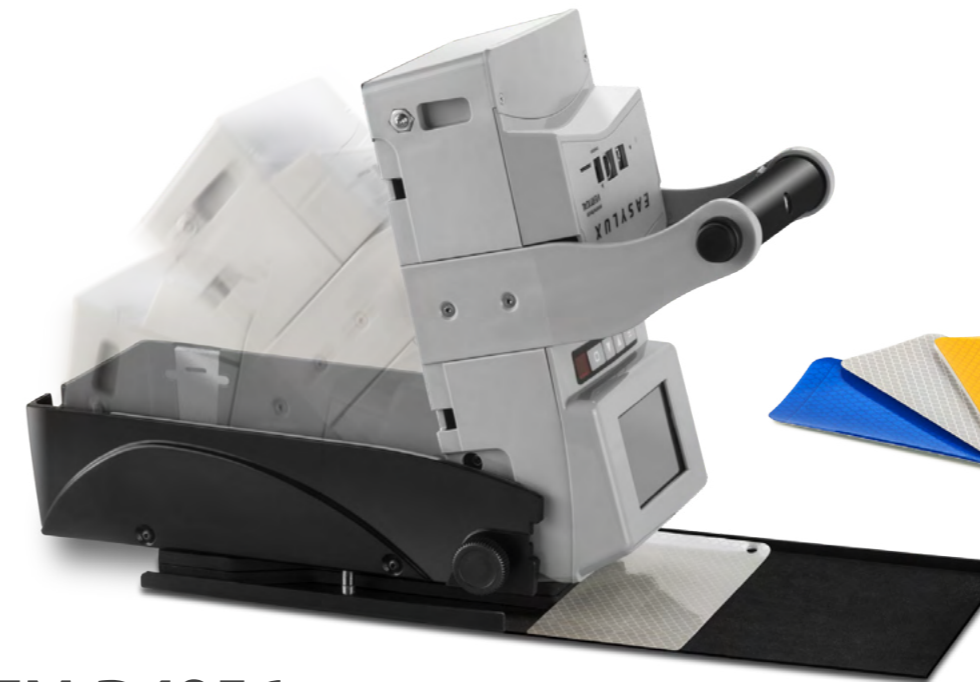

# ADJUSTABLE Illumination angle

With built-in digital inclinometer for precise entrance angle control from 0 to 90°

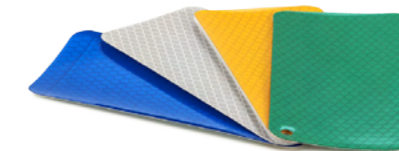

## Automatic Color Recognition

Identify and Measures all types and colors of retroreflective materials.

# ASTM D4956 ECE 104 ISO 20471

The combination of adjustable entrance angle with the exclusive quadruple simultaneous observation angles allows precise determination of retroreflection according ISO 20471 - *High Visibility Clothing* and ASTM D4956 - *Standard Specification for Retroreflective Sheeting for Traffic Control*.

## Sun proof technology

The exclusive external light suppression technology allows free access to the measurement area.

## DETAILED INFORMATION



### MINI Vertical Technical

Illumination angle	-4° / +5° and continuously adjustable 0 to 90°
Observation angle	Up to 4 simultaneous Available angles : 0.2°, 0.33°, 0.5°, 1.0°, 1.5° and 2.0°
Observation aperture	0.1° annular aperture.
Measurement area	28 mm
Measurement sensor	CIE V ( $\lambda$ ) adapted
Measurement range	$R_A$ : 0 - 2000 cd . lx <sup>-1</sup> . m <sup>2</sup>
Measurement time	1.2 s - 4 simultaneous observation angle
Standards	ASTM E1709, ASTM E2540, ASTM E1809, EN 12899-1, ECE 104, ISO 20471, DIN 67520, MUTCD, ABNT.

2 years warranty.

### Traceable Reference Standard

EasyLux Vertical uses a single reference standard to accurately measure all colors and types of materials. The reference is traceable to an accredited national standards laboratory.



# ISO 20471

## Retroreflectance of safety garments

The Easylux MINI Vertical retroreflectometer can implement 4 simultaneous observation angles. It is the only technology that is capable of fully complying with all requirements of ISO 20471 in a single unit. No special adaptors are needed.

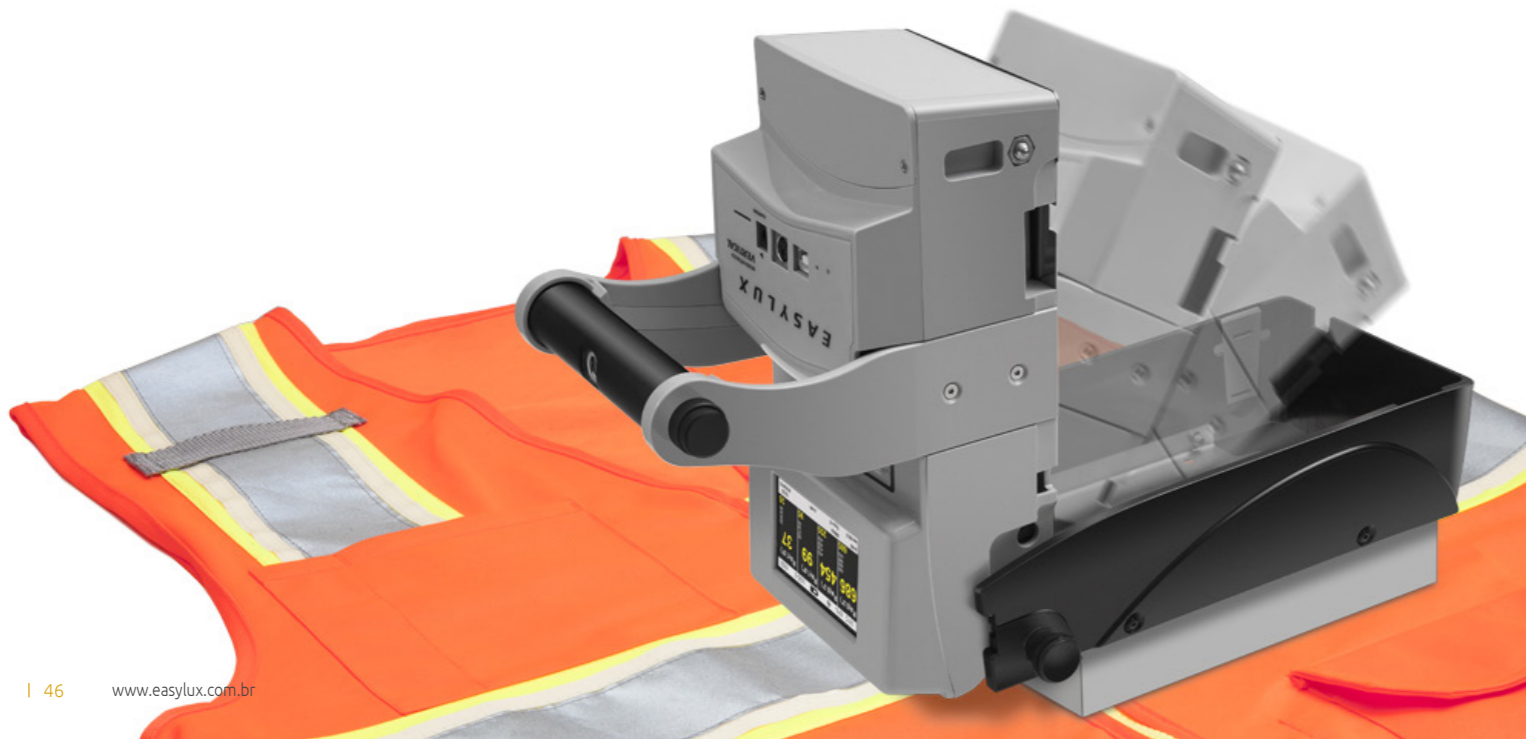

## MINI Vertical Features

- Available with 2 or 4 simultaneous angles .
- Suitable for safety clothing ISO 20471 and for ECE 104 inspection.
- Extension pole and IrDA remote control (optional).
- Free adjustment of Illumination Angle.
- Contactless - External light proof measurements.
- Built-in Digital Inclinometer for precise angle control.
- Temperature, humidity.
- GPS (optional).
- User removable SD Card (4 GB minimum) (> 1 000 000 data points).
- Color transfective (sun readable) LCD with touch screen.
- LED technology - almost maintenance-free.
- Airplane carry-on luggage compatible carrying case.
- Fast measurements 1.2 s , 4 observation angles.
- Register the date, time, GPS, humidity, temperature, angle, ...
- LOG facilities as road name, milestone, color, material type, ...
- Free EasyData software for data analysis and reports.
- Multiple languages.
- Averaging facilities with continuously updating values.
- User configurable Trigger timer and Stop timer.
- Automatic sign color recognition.



UP TO 4 ANGLES  
**SIMULTANEOUSLY**



# Road Studs

## Retroreflectometer

ASTM E1696 0.2° / 1°

EN 1463 0.3° / 1°

**MiniReflecto is the unique Dual Angle road studs retroreflectometer** in the world market.

The patented optical system was designed to measure the retroreflectance  $R_I$  of RRPM on site or in a laboratory with two simultaneous observation angles of 0.2° (or 0.3°) and 1°.



**FULL  
CONTROL**

Thanks to exclusive stray light suppression technology the user has full access to the measurement area.

It makes correct field positioning and precise entrance angle control possible.

## Road Studs Options

BlueTooth

WAAS

GPS

Ergonomic kit



## Dimensions and Weight

Length	255 mm
Width	155 mm
Height	170 mm
Weight	2.0 kg (with battery)
Carrying case	470 x 380 x 240 mm

## Electrical

Battery	Standard AA size (6 units)
Charger	Automatic 100-240 V full range
Data memory	SD Card (4 GB minimum) (> 1 000 000 data points)
Display	Color transfective, touch screen
Interface	USB, serial and Bluetooth (optional)
Operating	-10°C to 50°C
Light Source	LED light

# ALL TYPES AND COLORS



Measures all types and colors of road studs (RRPM) on site or in the laboratory.

## MINI Road Studs Technical

Illumination angle	1.0°
Observation angle	0.2° (or 0.3°) and 1°
Observation aperture	0.1°
Measurement area	75 mm x 30 mm
Measurement sensor	CIE V ( $\lambda$ ) adapted
Measurement range	R <sub>r</sub> : 0 - 2500 mcd . lx <sup>-1</sup>
Measurement time	1 second for each observation angle
Standards	ASTM E1696, EN1463

**2 years warranty.**

## Traceable Reference Standard

EasyLux Road Studs uses a single reference standard to accurately measure all colors and types of road studs. The reference standard is traceable to an accredited national standards laboratory.



## MINI Road Studs Features

- 2 simultaneous geometry: 0.2° (or 0.3°) and 1°.
- Free adjustment of entrance angle.
- External, light proof measurements.
- Full access to the measurement area at time of reading.
- Allows precise positioning on field.
- Easy entrance angle control.
- GPS (optional).
- User removable SD Card (4 GB minimum).
- Color, transfective (sun readable) LCD with touch screen.
- LED technology - almost maintenance-free.
- Airplane carry-on luggage compatible carrying case.
- Fast measurements: **1 second** for each observation angle.
- Register the date, time, GPS, humidity, temperature, tilt %, ...
- LOG facilities as road name, milestone, color, RRRPM type, ...
- Free EasyData software for data analysis and reports.
- Multiple languages.
- Averaging facilities with continuously updating value.
- User configurable Trigger timer and Stop timer.

# 2 ANGLES SIMULTANEOUSLY



# RETROREFLECTANCE KIT

It does not seem possible. That you can bring all retroreflectometers - road marking, road studs, road signs - into a single light box. But it is.



# CLASSIC



## Classic Horizontal

Released in 2006 as a robust and simple solution to road marking visibility control.



## Classic Vertical

Released in 2008 with an innovative LED light source system, the Easylux classic vertical retroreflector is very compact and simple.



## Classic Road Studs - RRPM

Released in 2009 as a laboratory instrument, the classic RRPM was redesigned to match critical field requirements as position and alignment control.

---

## Classic Products

Easylux classic retroreflectometers are designed with focus on simplicity and practicality.

All classic products use LED technology. It makes the instrument almost maintenance-free and energy efficient.

# HORIZONTAL

## Classic Retroreflectometer

EN1436	RL Qd
ASTM E1710	RL
ASTM E2302	Qd
ASTM E2177	RL wet

Available on :

- 15-meter geometry;
- 30-meter geometry;
- Dual 15/30 geometry.



**Easylux Horizontal Classic is robust, simple and intuitive handling**

**instrument** which can simultaneously evaluate nighttime visibility ( $R_L$ ), daytime visibility (Qd) and register the ambient temperature and relative air humidity quickly, easily and effortlessly.

## Classic Horizontal Technical

30-meter geometry	88.76° / 1.05° (ASTM E1710) 1.24° / 2.29° (EN1436)
15-meter geometry	86.5° / 1.5°
Measurement range	$R_L$ : 0 - 1999 mcd . m <sup>2</sup> . lx <sup>-1</sup> Qd: 0 - 320 mcd . m <sup>2</sup> . lx <sup>-1</sup>
Measurement area	70 x 190 mm
Measurement sensor	Multiple detectors - CIE V (λ) adapted
Measurement time	1 second for $R_L$ or 2 seconds for RL + Qd
Profiled markings	Up to 2 mm
Dimensions	590 x 160 x 260 mm
Weight	5.5 kg (with battery)
Standards	EN1436, ASTM E1710, ASTM E2176, ASTM E2302, NBR 14723 (15-meter).



## Electrical

Battery	V.L.R.A 12 V rechargeable
Charger	Automatic 100-240 V full range
Data memory	Internal 4000 measurements
Display	Character LCD with night vision
Interface	USB
Operating	-10°C to 70°C (extended range)
Light Source	LED light

**StrAusZert Germany test certificate No. 0913-2014-04**



The instrument comes with carrying case, calibration certificate, Easydata software tool, user's manual (English, Portuguese, Spanish and Italian), NIST traceable calibration standard, USB cable and a universal full-range battery charger.

## Classic Horizontal Features

- LED technology. Long-lasting battery.
- Internal memory for 4000 readings. USB computer interface.
- Extended temperature range: -10° C to 70° C.
- Free Easydata software for data analysis and reports (see page 45).
- NIST Traceable Standard (preformed glass beads) .
- WAAS GPS (optional).
- Temperature and Air Relative Humidity for every data.
- Programmable stop-timer and wet-timer.
- 4 languages menu (English, Portuguese, Spanish ,Italian).
- Available in single or dual geometry.
- Approved by StrAusZert Germany (certificate 0913-2014-04)
- 2 year warranty.



## Options

WAAS GPS

Ergonomic Kit

Qd - Daytime Visibility

Portable Serial Printer



# VERTICAL

## Classic Retroreflectometer

ASTM E1709

ASTM E2540

EN 12899-1

ISO 20471

Available on :

- Single angle.
- Dual angle.

**Easylux Vertical classic retroreflectometer is the most compact dual angle retroreflectometer in the world market.** Being only **180 mm wide and 860 g** weight, this practical instrument can measure the retroreflection ( $R_A$ ) of all type and colors of road signs and others materials fast and effortlessly.

## Options

GPS WAAS: 2.5 meter - 56 channel - WGS84

5 meter extension pole with remote control

Barcode reader

RFid tag reader ISO 15693 and ISO 1443A/B



The LED optic system is built according to CIE V( $\lambda$ ) specifications, enabling accurate measuring on colorful materials without the need of correcting factors.

## Classic Vertical Technical

Illumination angle	-4° or +5°
Observation angle	Up to 2 simultaneous . Available angles : 0.2°,0.33°,0.5°,1.0°
Observation aperture	0.1° annular aperture.
Measurement area	25 mm
Measurement sensor	CIE V ( $\lambda$ ) adapted
Measurement range	$R_A$ : 0 - 1999 cd . lx <sup>-1</sup> . m <sup>-2</sup>
Measurement time	1 second for each observation angle
Memory	Internal 4000 measurements
Interface	USB (Easydata software compatible)
Battery	LI-Ion 7.2 V
Standards	ASTM E1709, ASTM E1809, ASTM E2540, EN 12899-1, ISO 20471, DIN 67520, MUTCD, ABNT.

## Traceable Reference Standard

Easylux uses a single standard traceable to an accredited national standards laboratory.

2 years warranty.



# Illumination Adaptor

20°, 30°, 40°, 60°

ECE-104 Special Illumination Angle adaptors





# Road Studs

## Classic Retroreflectometer

ASTM E1696	0.2° / 1°
EN 1463	0.3° / 1°

### EasyLux Road Studs is a robust and very compact size

**retroreflectometer.** Weighing only 3 kg, this simple handling instrument can measure the retroreflection ( $R_r$ ) of all types and colors of road studs - RPM.

### Applications and Uses:

- Checking of road studs' visibility at field or laboratory.
- Inspection directly on field.
- Decision about renewal



The stray light suppression technology allows the user full access to the measurement area at time of reading. It makes correct field positioning and precise entrance angle control possible.

## Classic Road Studs Features

- Available in single or dual geometry.
- LED technology. Long-lasting battery.
- Stores over 4000 readings. USB computer interface.
- Extended temperature range: -10° C to 70° C.
- Free Easydata software for data analysis and reports (see page 45).
- WAAS GPS (optional).
- Registers the Temperature and the Relative Humidity for every data.
- 4 languages menu (English, Portuguese, Spanish , Italian).
- 2 year warranty.



## Classic Road Studs Technical

Illumination angle	0°
Observation angle	0.2° (or 0.3°) and 1°
Observation aperture	0.1° annular aperture.
Measurement area	135 mm x 30 mm
Measurement sensor	CIE V ( $\lambda$ ) adapted
Measurement range	$R_r$ : 0 - 2500 mcd . lx <sup>-1</sup>
Measurement time	1 second for each observation angle
Memory	Internal 4000 measurements
Interface	USB (Easydata software compatible)
Battery	Li-Ion 7.2 V
Dimensions	250 mm x 180 mm x 170 mm
Weight	3 kg (with battery)
Standards	ASTM E1946, EN 1463

## Traceable Reference Standard

EasyLux uses a single standard traceable to an accredited national standards laboratory.



# DYNAMIC

## Retroreflectometer

EN1436	RL
ASTM E1710	RL
ASTM E2177	RL wet
ASTM E2832	RL2 rain
ABNT 14723	15-meter

Available on :

- 15-meter geometry.
- 30-meter geometry.

**The Easylux Dynamic is the world's very first LED technology highway continuous retroreflectometer.**

The patented LED light source makes the equipment **energy efficient** and almost **maintenance-free**.

**Easylux Dynamic** measures the nighttime visibility  $R_L$  coefficient under strong sun light on dry or wet conditions. Profiled markings up to 20 mm can also be measured.

The LED optical system, combined with CIE eye sensor response  $V(\lambda)$  allows precise measurement of all types and colors of road marking at traffic speed (up to 120 km/h).



## EasyLux Dynamic Technical

30-meter geometry	88.76° / 1.05° (ASTM E1710) 1.24° / 2.29° (EN1436)
15-meter geometry	86.5° / 1.5°
Measurement range	R <sub>L</sub> : 0 - 1999 mcd . m <sup>2</sup> . lx <sup>-1</sup>
Measurement area	600 x 400 mm (16 channels)
Measurement sensor	Multiple detectors - CIE V (λ) adapted
Receiver aperture	0.33°
Profiled markings	Up to 20 mm
Dimensions	590 x 160 x 260 mm
Weight	11 kg
Working speed	Up to 120 km/h
Warranty	2 years
Standards	EN1436, ASTM E1710, ASTM E2176, ASTM E2302, NBR 14723 (15-meter).



The driver has control on the remote tablet of:

- Video overlay with position indicator.
- R<sub>L</sub> progression chart.
- Real time value and position bar diagram.
- Average values with user configurable integration space.
- Pre-programmed messages buttons (dust, rain, maintenance,...)

## EasyLux Dynamic Features

- Continuous R<sub>L</sub> measurements under dry or wet conditions.
- LED technology - almost maintenance-free.
- Works at any light condition (night and day) even over strong sun light.
- Real-time, high speed measurements.
- WAAS GPS - Mapping software compatible.
- Video overlay for driver guidance.
- Save pictures of all measured road markings.
- Driver can stop the data recording or register cue points
- Detect, record and classify road studs
- Free EasyData software for data analysis and Excel reports.
- Detect and measure double lines.
- Averaging facilities with continuously updating value.
- Universal car adaptor. Easy to mount on either car side.
- Removable front protection glass. Easy to clean and replace.
- Rear security alert flashing light.
- Extra panoramic camera for road surveillance (optional).
- Register date, time, GPS, temperature, relative air humidity, speed, pictures, driver alerts and other relevant data.



# MANAGE ROAD STUDS



Easylux Dynamic can detect, record and classify all road studs in measurement area.

The data collected by the measurement unit are stored on the central computer as .CSV and HTML reports. If necessary the data can be encrypted.

Double lines are measured individually with separate values for each line.

## Traceable Reference Standard

Easylux uses a single standard traceable to an accredited national standards laboratory.

## Electrical

Energy	12 V
Security	Rear flashing warning light
Image log	Up to 5 road marking pictures per second
Display	Tablet PC for driver assistance
Interface	USB
Operating	-10°C to 70°C (extended range)
Light Source	LED light



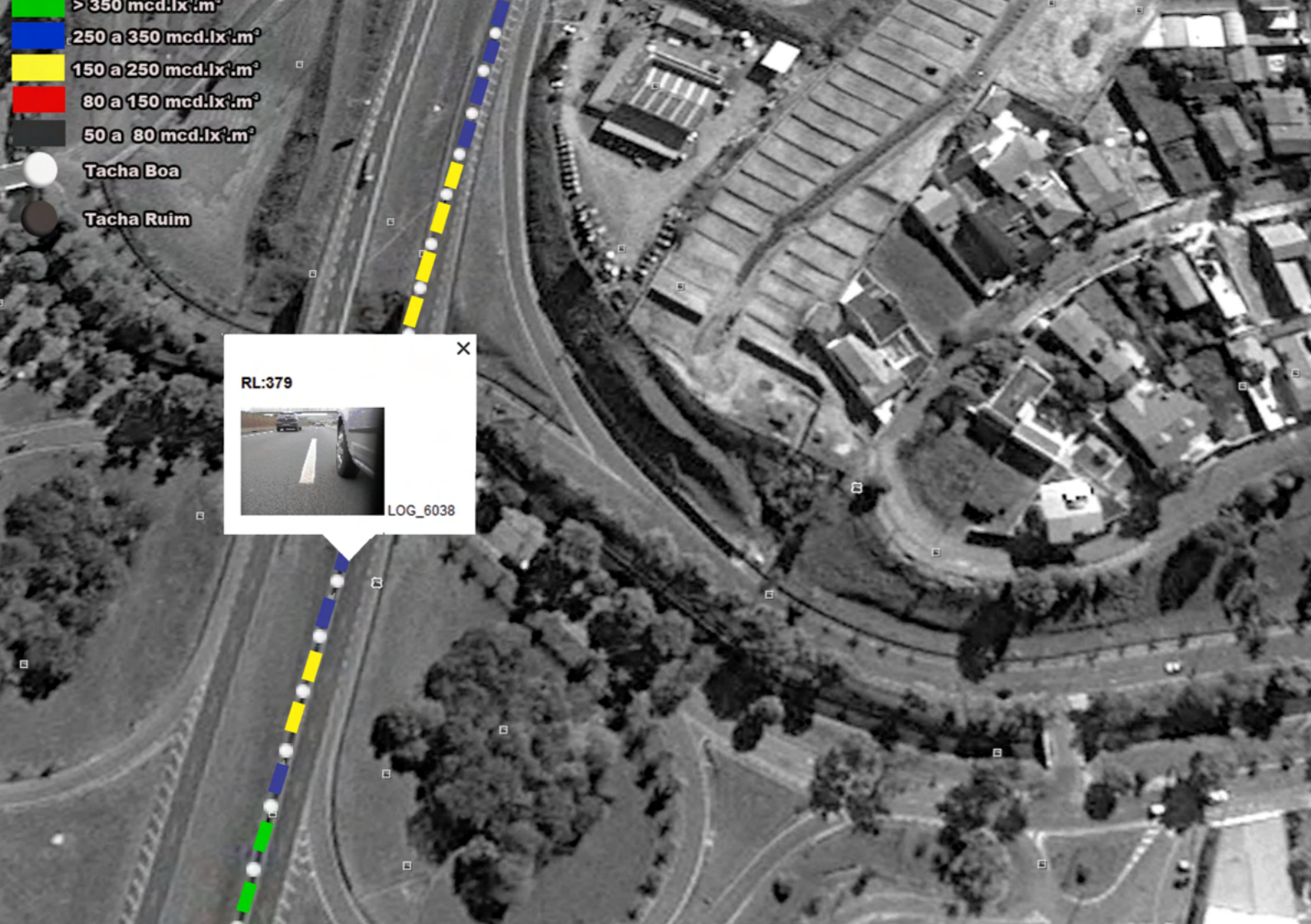

# EasyData

Software

**Easydata is a FREE software tool developed to manage measured figures of Easylux retroreflectometers.**

EasyData is supplied with ALL Easylux retroreflectometer models.

## COMPATIBLE DEVICES

Device	Description
MINI	All models of MiniReflecto (Horizontal, Vertical and Road Studs)
Classic	All models of classic retroreflectometers
Dynamic	30-meter and 15-meter models

Download data by USB, Bluetooth interface or read it from SD Card to generate reports and visual overview where measurements have been taken. All Data can be filtered by value range and color, exported as XLS, KML and displayed on the map:

- **Filter data by value and color**
- **Generate Excel measurements reports**
- **Display measured points on the map (GPS required)**

Measured data can be classified by value and color.

Automatically generates editable Excel measurement

Measurement Register - 1

km	RL	Qd	Color
0	183	180	White
0	170	66.8	Yellow
0	180	184	Red
0	215	184	Blue
0	19	0	White
0	23	0	White
0	21	0	White
0	19	34.3	White
0	130	163	White
0	275	234	White
0	171	147	White
0	246	229	White
0	190	183	White
0	278	202	White
0	190	172	White
0	275	197	White
0	259	166	White
0	152	111	White
0	278	157	White

**EASYLUX**
Easydata - V6.0.1

Menu
New
Excel

Filter

RL ▼  
 All values ▼  
 All colors ▼

km	RL	Qd	Color
0	183	180	White
0	170	66.8	Yellow
0	180	184	Red
0	215	184	Blue
0	19	0	White
0	23	0	White
0	21	0	White
0	19	34.3	White
0	130	163	White
0	275	234	White
0	171	147	White
0	246	229	White
0	190	183	White
0	278	202	White
0	190	172	White
0	275	197	White
0	259	166	White
0	152	111	White
0	278	157	White

Export KML.  
Google Earth compatible.



Automatic display measured values on the road map (GPS required).

# Services

**Each Easylux instrument by itself does not need re-calibration or special services** unless damaged by external factors.

To ensure reliable measurements, periodic checking of the instrument reference standard is recommended.

The user can buy a new calibrated reference standard to replace the old one or it can be checked independently with a special Easylux Calibration Kit (sold separately)

In case of damage or preventive maintenance, Easylux offers service of the instrument at our factory and re-calibration of the reference standards according to traceable references.

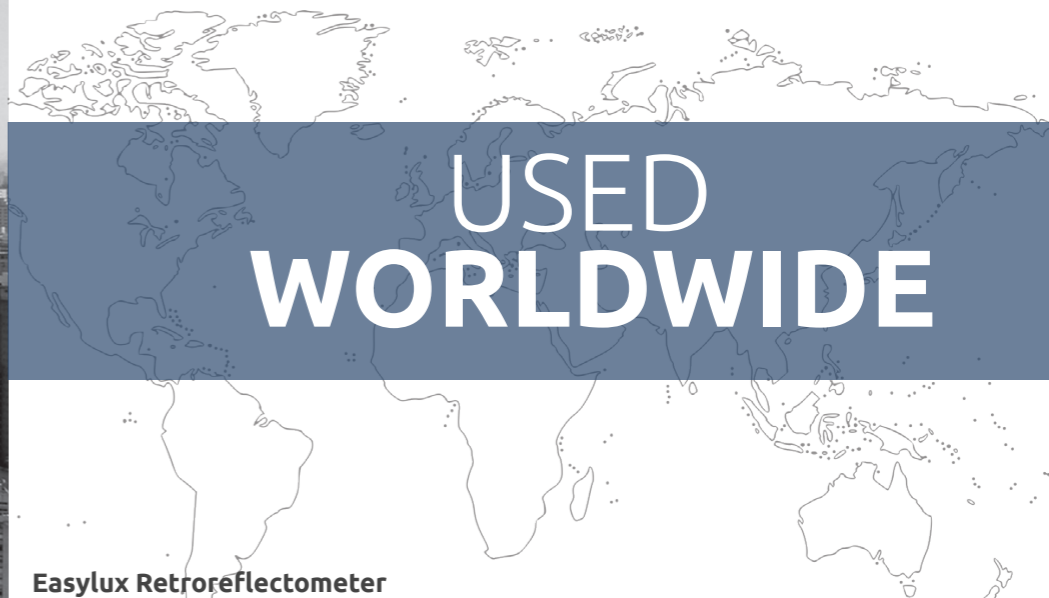

**Easylux Retroreflectometer**  
Av. Artur de Queiros, 780  
Santo André - SP - Brazil.  
CEP: 09015-510

Phone: +55 11 3438 3448  
Phone: +55 11 2564 4868  
vendas@easylux.com.br

# Looking far ahead

Horizontal retroreflectometer timeline.



**2006**

8 kg

670 mm length

LED optical system

Big and heavy instruments are unsafe and not suitable for road visibility control.



**2007**

6 kg

580 mm length

LED optical system



**2009**

5.5 kg

550 mm length

LED optical system



**2014**

2.1 kg

250 mm length

Today, Easylux holds the most advanced retroreflectometer optoelectronic technology.

The MINI for road markings is the result of an ambitious project. Being unconventional didn't matter, we were determined to make all efforts to build the best instrument in the world.

All preconceived ideas about were questioned and reinvented.

Throughout the development we erased the requirements and rewrote it again several times.

**We are placing a new market milestone.**

No other retroreflectometer in the world can match the size, the design, the performance and the weight of the new MINI, It simply can not be done.



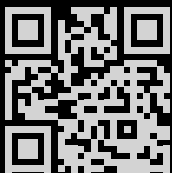

October 2015

[www.easylux.com.br](http://www.easylux.com.br)

